

# TOP PIER PLATFORMS WITH GROUT HOLE

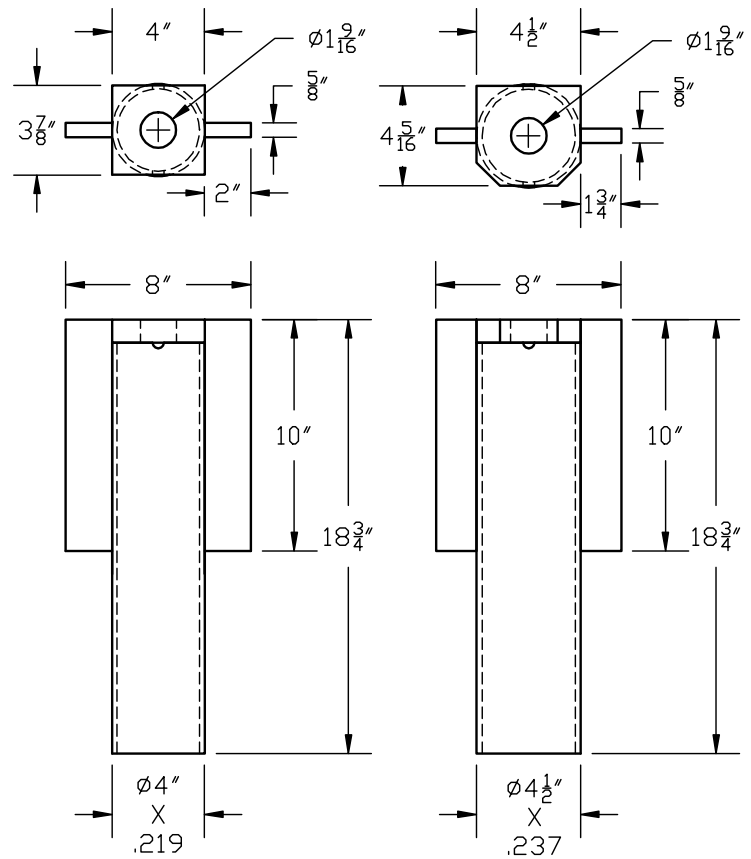

PART#	DESCRIPTION	PART#	DESCRIPTION
PSA1002N	AP-2-TPP-3500H[P]	PSA1095N	AP-2-TPP-3500HM[P]
PSA1053N	AP-2-TPP-3500H[G]	PSA1105N	AP-2-TPP-3500HM[G]

-NOTES-

1. TOP PIER PLATFORM FINISH AVAILABLE IN PLAIN [P] OR HOT DIP GALVANIZED [G] PER ASTM A153-(LATEST REVISION),
2. MATERIAL SPECIFICATIONS:  
 PIPE MATERIAL PER ASTM A513/1 OR ASTM A500 GRADE B OR A53 TYPE A.  
 PLATE MATERIAL PER ASTM A36.
3. ALL WELDING TO BE DONE BY WELDERS CERTIFIED UNDER SECTION 5 OF THE AWS CODE D1.1.
4. MANUFACTURER TO HAVE IN EFFECT INDUSTRY RECOGNIZED WRITTEN QUALITY CONTROL FOR ALL MATERIALS AND MANUFACTURING PROCESSES.

<b>ATLAS</b>	<b>HUBBELL POWER SYSTEMS</b>		
<b>TOP PIER PLATFORMS WITH GROUT HOLE</b>			
CONFIDENTIAL: THIS DRAWING AND ITS CONTENTS ARE CONFIDENTIAL AND THE EXCLUSIVE PROPERTY OF HUBBELL POWER SYSTEMS, INC. NO PUBLICATION, DISTRIBUTION OR COPIES MAY BE MADE WITHOUT THE PRIOR WRITTEN CONSENT OF HUBBELL POWER SYSTEMS, INC. HUBBELL POWER SYSTEMS UNPUBLISHED ALL RIGHTS RESERVED UNDER THE COPYRIGHT LAWS.	TITLE	SIZE	DWG NO.
		A	SA1002N
	CAT / PART / ASSY NO.	SEE DWG	
DO NOT SCALE THIS DRAWING	DRN BY SMS	DATE 9/12/07	SHEET 1 OF 1