

TYPICAL INSTALLATION  
FOUNDATION REPAIR BRACKET

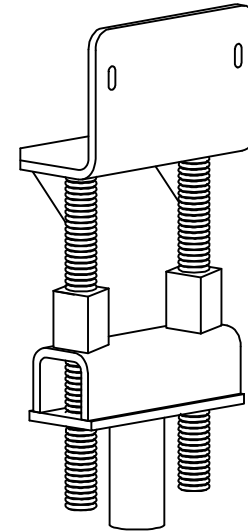
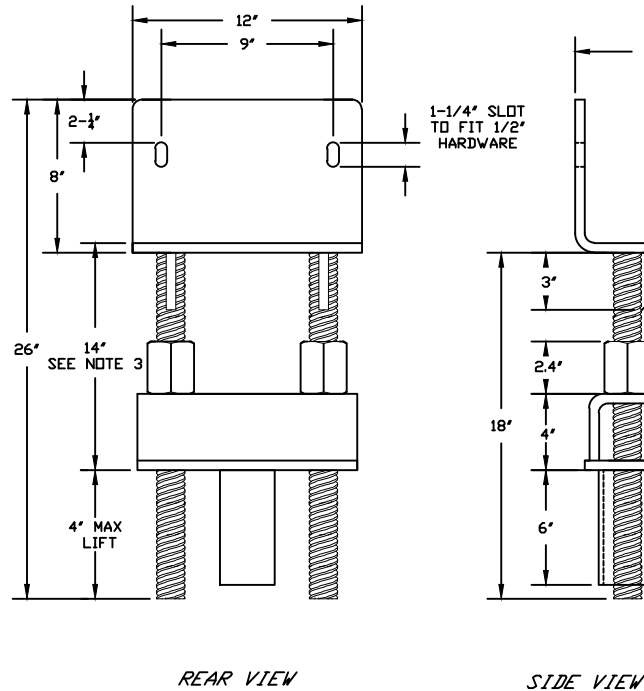

-NOTES-

1. HOT DIP GALVANIZE PER ASTM A153-(LATEST REVISION).
2. ASSEMBLE COMPLETE AS SHOWN IN SIDE VIEW.
3. RECOMMENDED ANCHOR SHAFT CUTOFF LEVEL BELOW THE BOTTOM OF THE FOOTING IS 14.5' FOR MAXIMUM LIFT DISTANCE.
4. MATERIAL SPECIFICATIONS:  
BRACKET BODY : 1/2" THICK STEEL PER ASTM A36 LATEST REV.  
T-PIPE TUBE BODY : STEEL PER ASTM A572 GRADE 50, LATEST REV.  
T-PIPE PIPE : STEEL PIPE PER ASTM A500 LATEST REV.  
LIFTING STUDS: WILLIAMS FORM #11 GRADE 90.
5. A FACTOR OF SAFETY OF 2 YIELDS A SAFE WORKING LOAD.
6. THE CAPACITY OF THE UNDERPINNING SYSTEM IS A FUNCTION OF MANY INDIVIDUAL ELEMENTS, INCLUDING THE CAPACITY OF THE FOUNDATION, BRACKET, PIER SHAFT, HELICAL PLATE, AND BEARING STRATA, AS WELL AS THE STRENGTH OF THE FOUNDATION TO BRACKET CONNECTION AND THE QUALITY OF PIER INSTALLATION.

SHAFT SIZE	CAT. NUMBER	MINIMUM ULTIMATE STRENGTH	WORKING LOAD
SS150/SS5	C1500738	70,000 LBS	35,000 LBS
SS175	C1500733	100,000 LBS	50,000 LBS

CHANCE <sup>®</sup> TOLERANCE CHART		HUBBELL <sup>®</sup> POWER SYSTEMS POWER SYSTEMS, INC.	
CONFIDENTIAL: THIS DRAWING AND ITS CONTENTS ARE CONFIDENTIAL AND THE EXCLUSIVE PROPERTY OF HUBBELL POWER SYSTEMS. NO PUBLICATION, DISTRIBUTION OR COPIES MAY BE MADE WITHOUT THE WRITTEN CONSENT OF HUBBELL POWER SYSTEMS. HUBBELL POWER SYSTEMS UNPUBLISHED. ALL RIGHTS RESERVED UNDER THE COPYRIGHT LAWS.		TITLE BRACKET, DIRECT JACK	
SIZE SB	DWG NO. SA1500733	CAT / PART / ASSY NO. SEE CHART	REV B
DO NOT SCALE THIS DRAWING	DRN BY JCA	DATE 2/18/10	SHEET 1 OF 1