

RS2875.203 LEADS

TORQUE STRENGTH RATING-5,500 FT-LB
 ULTIMATE CAPACITY* (TENSION/COMPRESSION) 49 KIP
 *BASED ON A TORQUE FACTOR (Kt)=9

=NOTES=

1. HOT DIP GALVANIZED PER ASTM A153-(LATEST REVISION) C278-4510 ONLY
2. LEAD EFFECTIVE AND PILOT POINT LENGTHS ARE NOMINAL.
3. PIPE SHAFT MATERIAL 2.5" NOMINAL, SCHEDULE 40 WALL THICKNESS PER ASTM A500 GRADE B.
4. DRIVE PLATE SCREWS PIPE SHAFT DOWN TO ROCK
5. MANUFACTURER TO HAVE IN EFFECT INDUSTRY RECOGNIZED WRITTEN QUALITY CONTROL FOR ALL MATERIALS AND MANUFACTURING PROCESSES.
6. ALL WELDING TO BE DONE BY WELDERS CERTIFIED UNDER SECTION 5 OF THE AWS CODE D1.1.
7. FOR ADDITIONAL PIPE SHAFT LENGTH, REFER TO DRAWING SA278-4500 LIFT PILE EXTENSIONS.

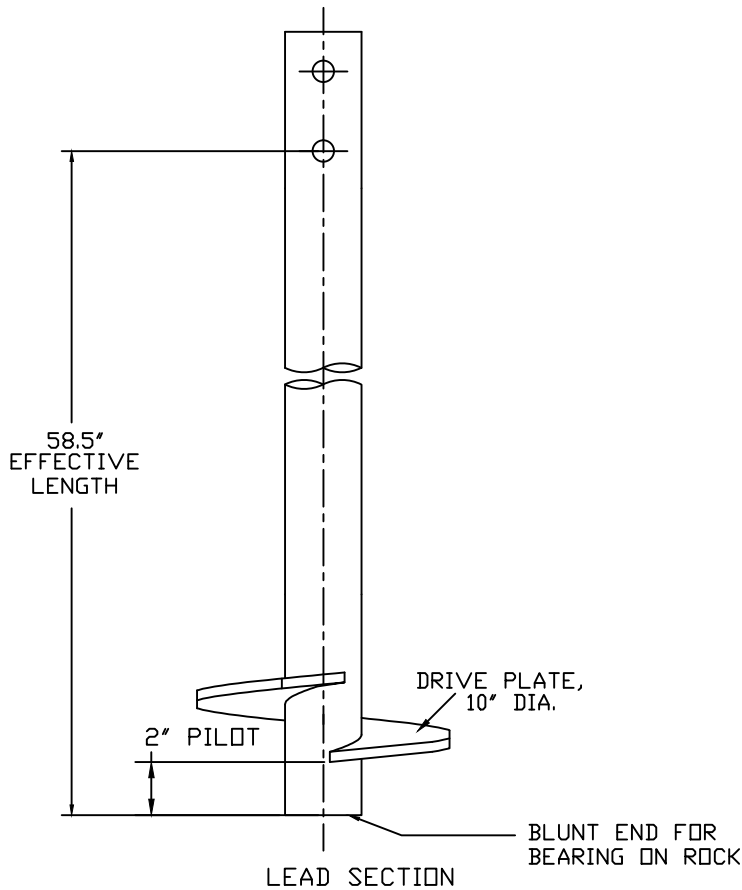
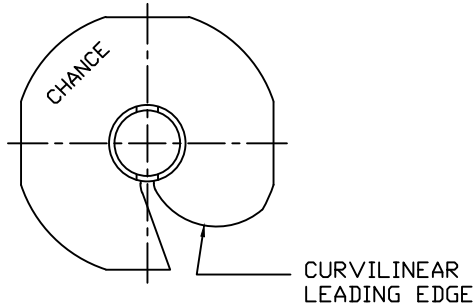

CATALOG NUMBER	DESCRIPTION
C278-4510	RS2875.203 LEAD, 58.5'
C278-4510NG	RS2875.203 LEAD, 58.5', NON-GALV

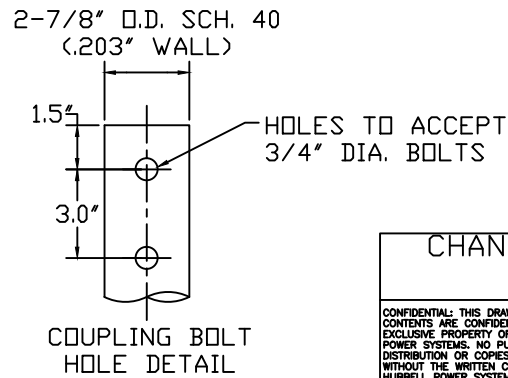

CHANCE		 HUBBELL POWER SYSTEMS <small>POWER SYSTEMS, INC.</small>	
<small>CONFIDENTIAL: THIS DRAWING AND ITS CONTENTS ARE CONFIDENTIAL AND THE EXCLUSIVE PROPERTY OF HUBBELL POWER SYSTEMS. NO PUBLICATION, DISTRIBUTION OR COPIES MAY BE MADE WITHOUT THE WRITTEN CONSENT OF HUBBELL POWER SYSTEMS. HUBBELL POWER SYSTEMS UNPUBLISHED. ALL RIGHTS RESERVED UNDER THE COPYRIGHT LAWS.</small>			
TITLE		RS2875.203	
PILE, LEAD			
SIZE	DWG NO.	CAT / PART / ASSY NO.	REV
SC	SA278-4510	SEE CHART	C
DO NOT SCALE THIS DRAWING	DRN BY KSH	DATE 2/14/05	SHEET 1/1