

Chance® Helical PSAC1500499 Low Profile Bracket and T-Pipe System

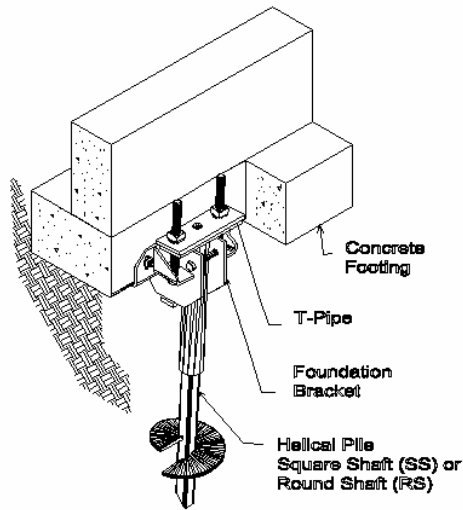

- Use for lifts up to 4" (10 cm)
- All PSAC1500499 Standard Systems include:
 - Foundation bracket
 - T-pipe
 - Hardware

Order separately: Two 1/2" (13 mm) diameter anchor bolts per pier as required.

Standard finish is galvanized per ASTM A153.

Ultimate mechanical strength of bracket body is 30,000 lbs (133 kN). Working mechanical strength of bracket body is 15,000 lbs (67 kN).

See table below for system (bracket/pile shaft) ratings.

Chance® Helical PSAC1500499 Low Profile Bracket and T-Pipe Ratings					
T-Pipe Designations for the PSA1500499 Bracket	Ultimate Mechanical Strength ^{1,3} lbs (kN)	Pile Size in (mm)	Product Series	Max Working Capacity ^{2,3} based on Product Series lbs (kN)	Features
PSAC1500503	30,000 (133)	1-1/2 (38) Square	SS5 SS150	15,000 (67)	Lowest cost with Type SS5 Product Series
PSAC2780003	30,000 (133)	2-7/8 (73) Round	RS2875.165 RS2875.203	15,000 (67)	Lowest cost with Type RS2875.165 Product Series

Notes:

1. Ultimate mechanical strength is for the Bracket Body and T-Pipe combination.
2. The capacity of Chance® Helical Pile Systems is a function of many individual elements, including the capacity of the foundation, bracket, pile shaft, helix plate and bearing stratum, as well as the strength of the foundation-to-bracket connection, and the quality of the helical pile installation. The fifth column shows typical working capacities of the Chance® Helical Pile System based upon maximum shaft exposure of 2 feet and soil strength having a minimum Standard Penetration Test (SPT) Blow Count "N" of 4. Actual capacities could be higher or lower depending on the above factors.
3. The ultimate capacity of the system, i.e., bracket, T-pipe, and pile shaft, can be increased to the pile shaft compression capacity limit as shown on pages 7-22 and 7-32 provided the pile shaft is reinforced using a pipe sleeve or grout column. The maximum working capacity shall not be greater than one half the ultimate mechanical strength of the bracket and t-pipe combination given above.
4. These products comply with the 1997 Uniform Building Code, the 1999 BOCA National Code, and the 1999 SBCCI Standard Code subject to the conditions as listed in the Legacy Reports in Appendix C.